

Operating Instructions

STA 1 sectional door operator

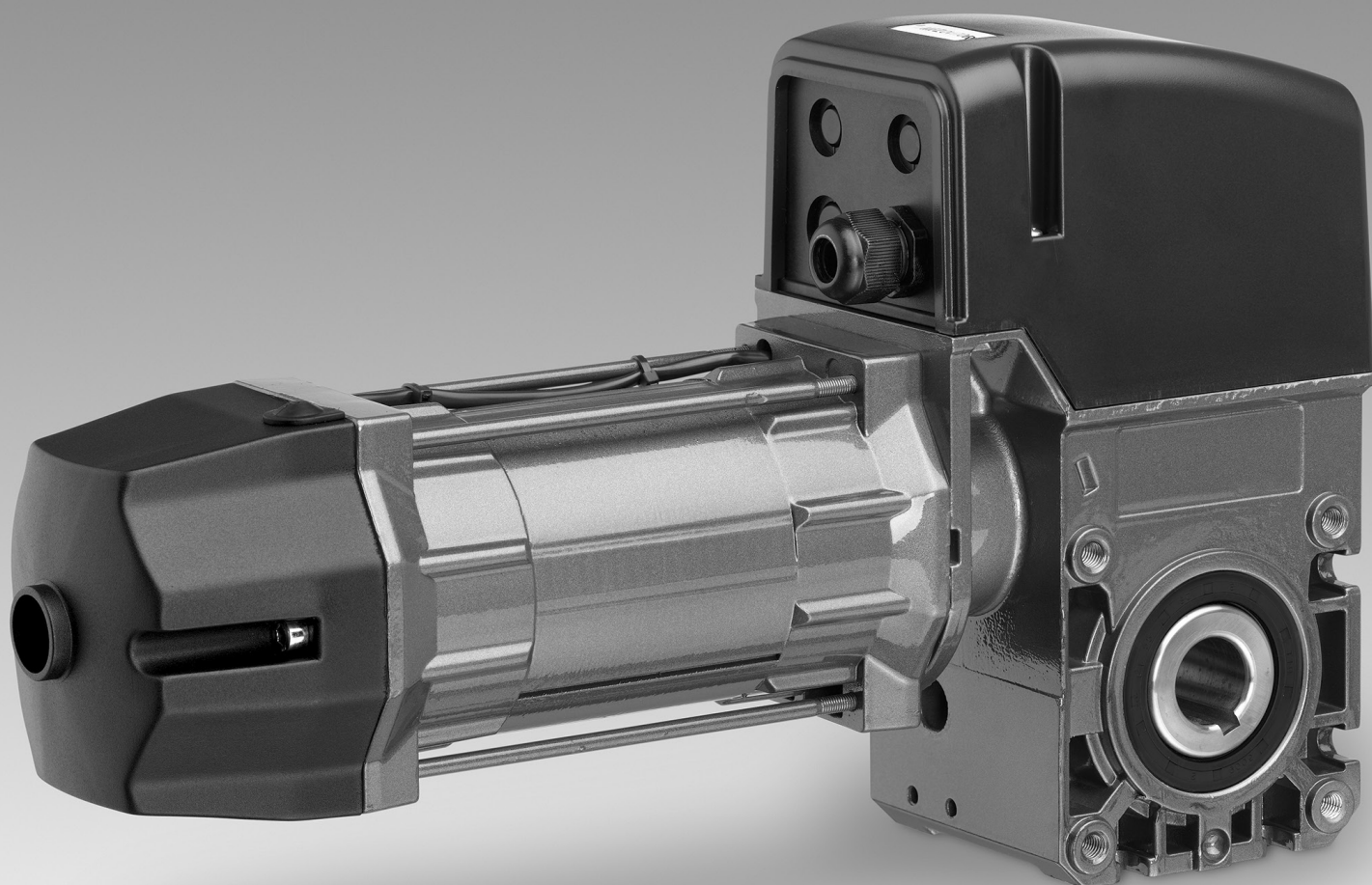

1. Contents

1.	Contents	2
2.	Information in this document	2
3.	General safety instructions	3
4.	Overview of products	4
5.	Installation	5
5.1	Preparation.....	5
5.2	Push-on assembly.....	5
5.3	Installation of the emergency hand chain (only for operators with emergency hand chain).....	6
6.	Initial Operation	7
6.1	Preparation.....	7
6.2	Connection.....	7
6.3	Manual settings	9
6.4	Digital settings – Limit switch and safety circuit for drive ...	10
6.5	Check the system	11
7.	Emergency operation	12
8.	Maintenance	13
9.	Technical data	14
10.	Manufacturer's Declaration	22

2. Information in this document

Original operating instructions

- Copyright.
- No part of these instructions may be reproduced without our prior approval.
- Subject to alterations in the interest of technical progress.
- All dimensions given in mm.
- The diagrams in this manual are not to scale.

Key to symbols

DANGER!

Indicates a hazard with a high level of risk which, if not avoided, will result in death or serious injury.

WARNING!

Indicates a hazard with a medium level of risk which, if not avoided, could result in death or serious injury.

CAUTION!

Indicates a hazard with a low level of risk which, if not avoided, could result in minor or moderate injury.

ATTENTION!

Indicates an imminent danger of damage or destruction.

CHECK

Indicates a check to be performed.

REFERENCE

Reference to separate documents which must be complied with.

Action request

- List, itemisation

→ Reference to other sections of this document

3. General safety instructions

DANGER!

Failure to observe the instructions in this document can result in mortal danger!

 Observe all safety information contained in this document.

Warranty

The function and safety of the equipment is only guaranteed if the warning and safety instructions included in these operating instructions are adhered to.

MFZ Antriebe GmbH & Co. KG is not liable for personal injury or damage to property if these occur as a result of the warnings and safety advice being disregarded.

MFZ does not accept any liability or warranty for damage due to the use of non-approved spare parts and accessories.

Intended use

The operators of the STA 1 range are designed exclusively for opening and closing weight counterbalanced sectional doors.

Target group

Only qualified and trained specialists are permitted to install and service the operator. Qualified and trained professionals fulfil the following requirements:

- knowledge of the general and specific safety and accident prevention regulations,
- knowledge of the relevant regulations,
- trained in the use and care of appropriate safety equipment,
- Capable of recognising the dangers associated with installation.

Only qualified and trained electricians may connect the operator and carry out electrical maintenance.

Qualified and trained electricians fulfil the following requirements:

- knowledge of the general and specific safety and accident prevention regulations,
- knowledge of the relevant electrical regulations,
- trained in the use and care of appropriate safety equipment,
- capable of recognising the dangers associated with electricity.

Instructions regarding installation, connection and maintenance

- The controls must be disconnected from the electricity supply before carrying out electrical works. It must be ensured that the electricity supply remains disconnected during the works.
- Local protective regulations must be complied with.
- Mains cables and control cables must be laid separately.

Observe the valid standards and regulations!

4. Overview of products

The following package options are available for the STA 1 operator:

- STA/STAW 1 E (external control unit with release mechanism)
- STA/STAW 1 KE (external control unit with chain)
- STA/STAW 1 KU (external control unit with emergency hand crank)

- STA/STAW 1 E - HD (external control unit with release mechanism, HD*)
- STA/STAW 1 KE - HD (external control unit with chain, HD*)
- STA/STAW 1 KU - HD (external control unit with emergency hand crank, HD*)

- STAC/STAWC 1 E (integrated control unit with release mechanism)
- STAC/STAWC 1 KE (integrated control unit with chain)
- STAC/STAWC 1 KU (integrated control unit with emergency hand crank)

* HD = Operators with this suffix have a higher duty cycle.

The precise values for all operators can be found in
→ „9. Technical data”

Additional product combinations are possible.
Information about these combinations can be obtained from the manufacturer.

5. Installation

5.1 Preparation

! WARNING!

Incorrect installation of the drive can result in serious injury!

- The drive must be installed free of any tension.
- The drive must not move on the shaft.
- The design and subsurface of all components must be suitable for the forces encountered.
- Installation must only be carried out from a safe standing position (e. g. scaffolding).

! ATTENTION!

Incorrect installation of the drive can result in damage to property!

To avoid damage to the drive and the door, the drive must only be fitted if

- the drive is undamaged,
- the ambient temperature is -20 °C to +60 °C.,
- the altitude of the location does not exceed 1,000 m,
- a suitable protection type has been selected.

- 👉** Before installation, ensure that
- the drive is not blocked,
 - the drive has been newly prepared after a lengthy storage period,
 - all connections have been carried out correctly
 - the direction of rotation of the drive motor is correct,
 - all motor protective devices are active
 - no other sources of danger exist,
 - the installation site has been cordoned off over a wide area.

5.2 Push-on assembly

! ATTENTION!

Damage due to improper installation of the drive!

To avoid damage to the drive and to the door, the drive must be mounted on a console or a torque support bracket so that it is vibration damped.

i REFERENCE

The relevant instructions for the door must be observed when fitting the drive to the door.

Solid shaft

5.2 / 1

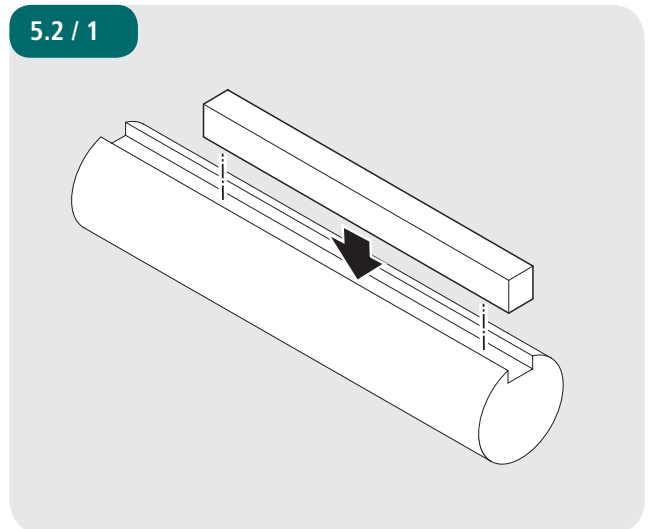

Check whether the feather key is suitable for the spring shaft on site.

Installation

Mounting with torque support bracket

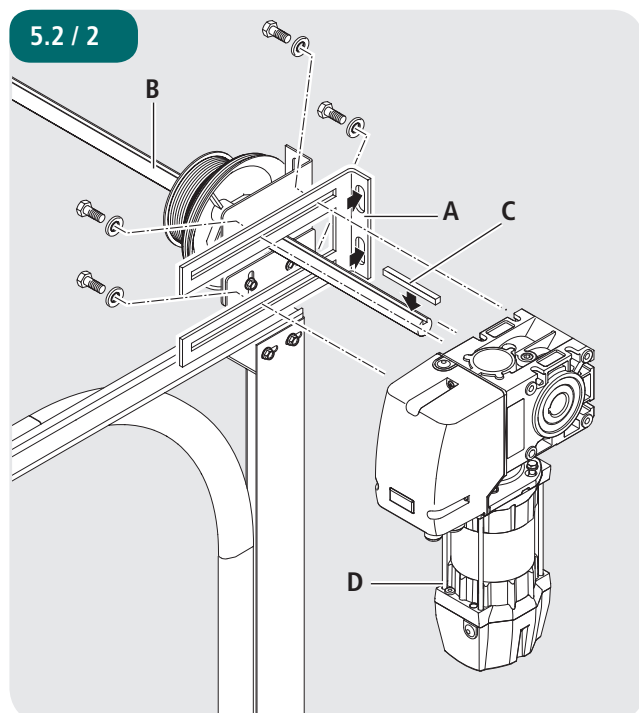

- Fit the torque support bracket/console (A).
- 🔧 Grease the spring shaft (B) around the operator seating.
- 🔧 Insert the feather key (C) into the spring shaft (B).
- 🔧 Place the operator (D) on the spring shaft (B).
- 🔧 Secure the feather key (C) against any movement.

The feather key can be secured with two hose clamps or adjusting rings.

- 🔧 Fix the operator to the torque support bracket with 4 screws.

5.3 Installation of the emergency hand chain (only for operators with emergency hand chain)

To ensure that they work correctly, the chain links must not be twisted.

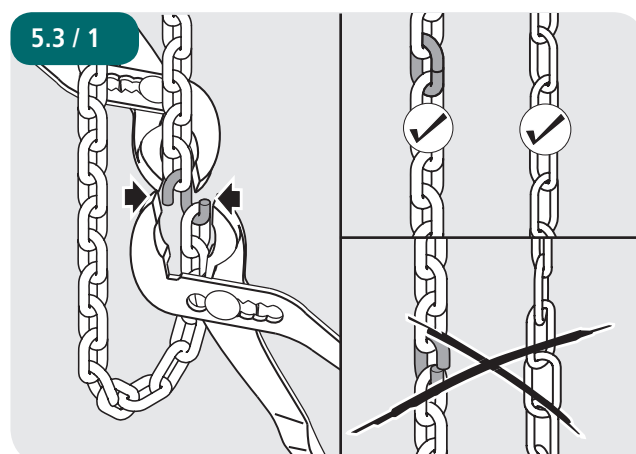

- 🔧 Join the ends of the emergency hand chain together with the chain connecting link.

ATTENTION!

Incorrect operation of the drive can result in damage to property!

To avoid damage to the drive and the door, the emergency hand chain must be secured while the door is operated electrically.

6. Initial Operation

6.1 Preparation

DANGER!

Danger of fatal electric shock!

-  Before commencing cabling works, you **MUST** disconnect the drive system from the mains supply. Ensure that the electricity supply remains disconnected throughout the cabling works.

ATTENTION!

Damage due to improper installation of the drive!

To avoid damage to the drive, the following points must be observed:

- The types of cable and their diameters must be selected according to current regulations.
- The nominal currents and the type of connection must correspond to those on the motor type plate.
- The drive details must agree with the connected loads.

REFERENCE

When operated with electronic control units, the corresponding start-up instructions and circuit diagrams must be complied with.

6.2 Connection

Open the operator

6.2 / 1

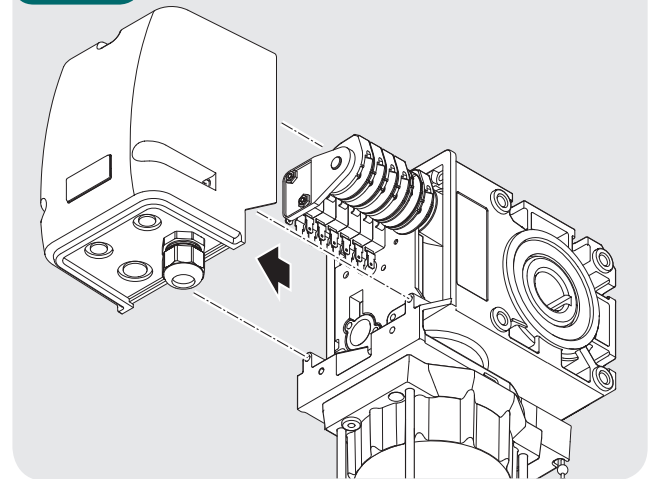

-  Remove the cover from the operator.

Insert the cables

6.2 / 2

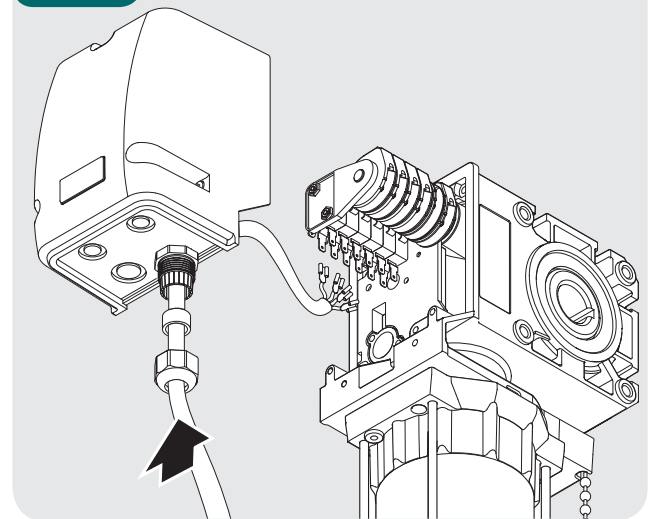

-  Feed the cables through the screw fitting into the operator.

Initial Operation

Limit switch connections (plug-in, standard)

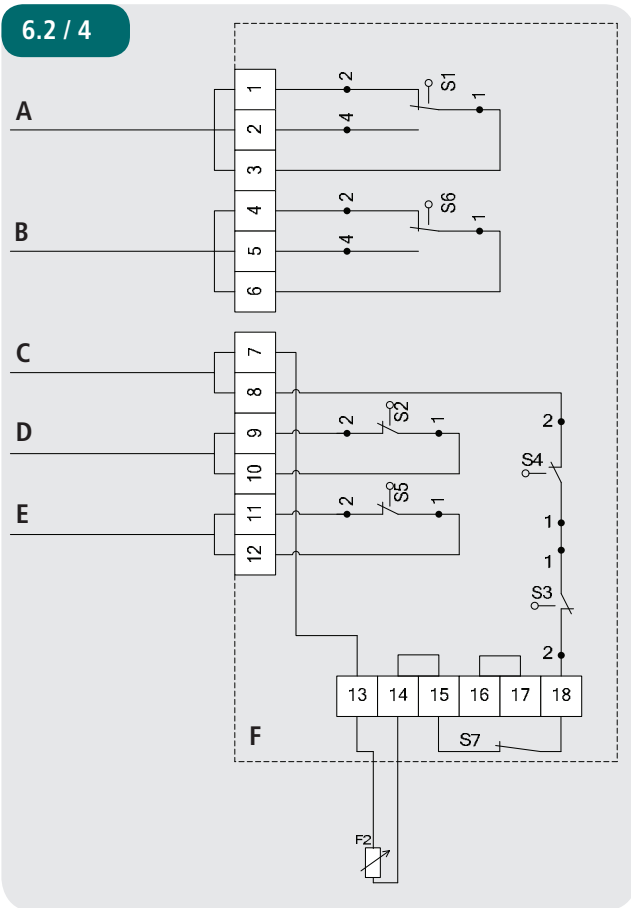
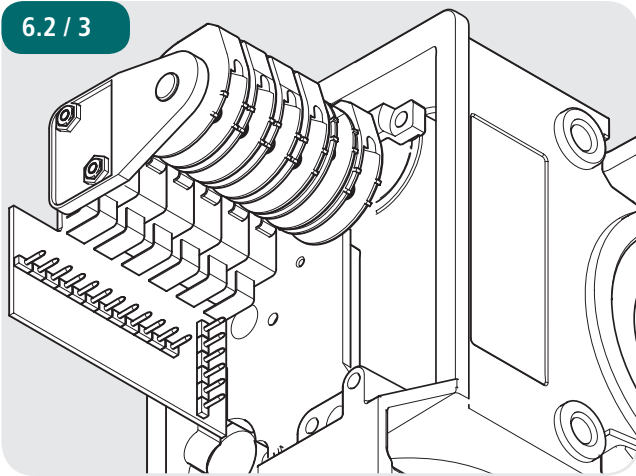

- A Potential-free connection OPEN
- B Potential-free connection CLOSE
- C Switch off safety circuit
- D Switch off OPEN end position
- E Switch off CLOSED end position
- F Internal safety circuit

- S1 Additional limit switch, OPEN (standard only for operators without integrated control unit)
- S2 Limit switch, OPEN
- S3 Safety limit switch, OPEN
- S4 Safety limit switch, CLOSED
- S5 Limit switch, CLOSED
- S6 Additional limit switch, CLOSED (standard only for operators without integrated control unit)
- S7 Safety limit switch for emergency manual operation
- F2 Thermal overload protection for motor

Limit switch connections

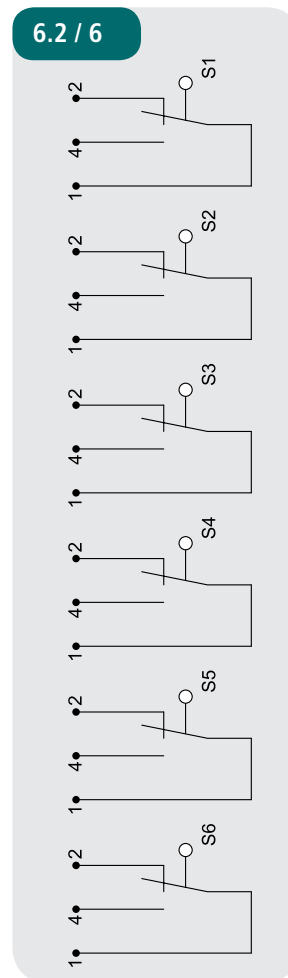
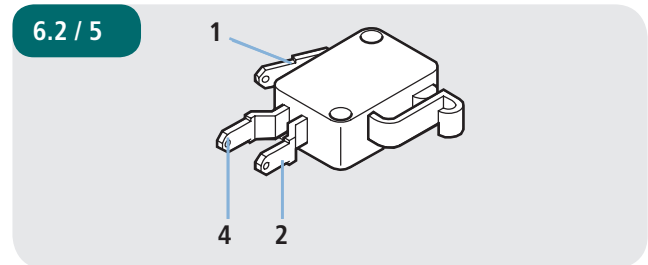

- S1 OPEN additional limit switch (standard only in the case of operators without integrated control unit)
- S2 Limit switch, OPEN
- S3 Safety limit switch, OPEN
- S4 Safety limit switch, CLOSE
- S5 Limit switch CLOSED
- S6 CLOSED additional limit switch (standard only in the case of operators without integrated control unit)

3 x 400 V star connection (standard)

The motor is factory-wired for connection to a 3 x 400 V mains supply in star connection.

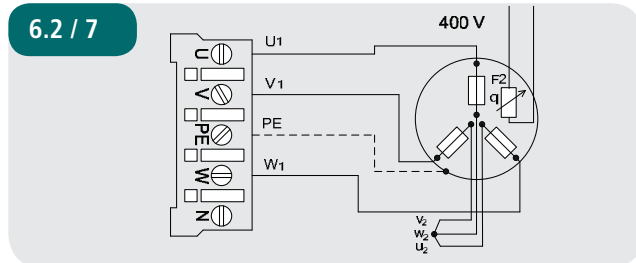

🔧 Connect all the cables required.

Identification of wires

U1	Red
V1	Blue
W1	White
V2	Black
W2	Brown
U2	Green

3 x 230 V delta connection

To connect the operator to a 3 x 230 V mains supply, please consult the manufacturer.

1 x 230V connection

The motor is factory-wired for connection to a 230V/1-phase mains supply.

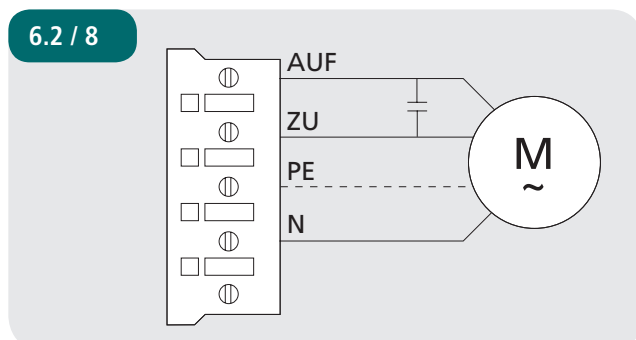

🔧 Connect all the cables required.

Identification of wires

AUF (OPEN)	blue
ZU (CLOSE)	blue
N	red

6.3 Manual settings

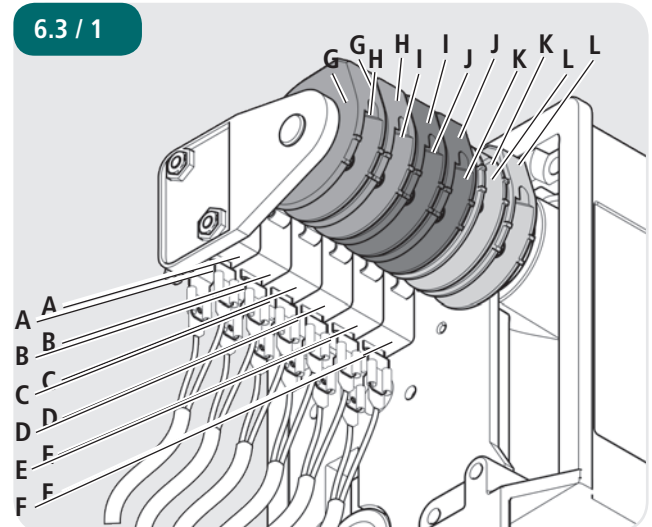

- A OPEN additional limit switch - S1 (potential-free change-over contact)
- B Limit switch, OPEN - S2
- C Safety limit switch, OPEN - S3
- D Safety limit switch, CLOSED - S4
- E Limit switch, CLOSED - S5
- F Additional limit switch, CLOSED - S6 (potential-free change-over contact)
- G Control cam for additional limit switch, OPEN (green)
- H Control cam for limit switch, OPEN (green)
- I Control cam for safety limit switch, OPEN (red)
- J Control cam for safety limit switch, CLOSED (red)
- K Control cam for limit switch, CLOSED (white)
- L Control cam for additional limit switch, CLOSED (white)

Initial Operation

6.3 / 2

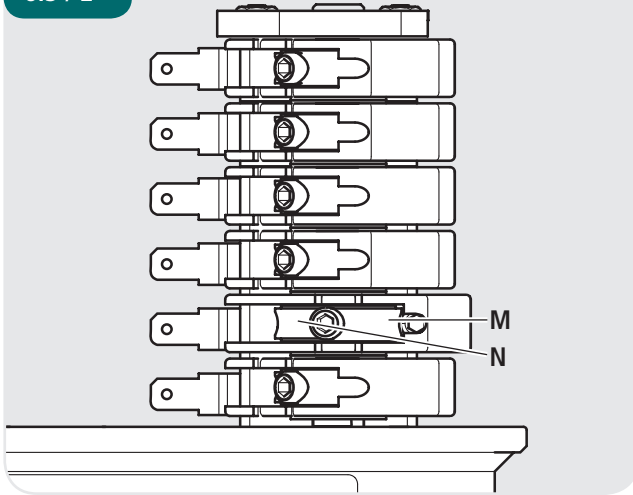

- M Fine adjustment screw
- N Locking screw

Each control cam has a locking screw (N) and a fine adjustment screw (M).

The locking screw (N) is used to lock the corresponding control cam in the desired position. Finer adjustment can be made with the fine adjustment screw (M).

Set the CLOSED end position

- Drive the door to the CLOSED end position.
- Set the control cam (K) so that the CLOSED limit switch (E) is actuated.
- Tighten the locking screw (N).

The CLOSED safety limit switch (D) must be set in such a way that it switches immediately when the CLOSED limit switch (E) is passed over.

- Adjust the CLOSED safety limit switch (D).

Set the OPEN end position

- Drive the door to the OPEN end position.
- Set the control cam (H) so that the OPEN limit switch (B) is actuated.
- Tighten the locking screw (N).

The OPEN safety limit switch (C) must be set in such a way that it switches immediately when the OPEN limit switch (B) is passed over.

- Adjust the OPEN safety limit switch (C).

6.4 Digital settings – Limit switch and safety circuit for drive

Electronic interface

6.4 / 1

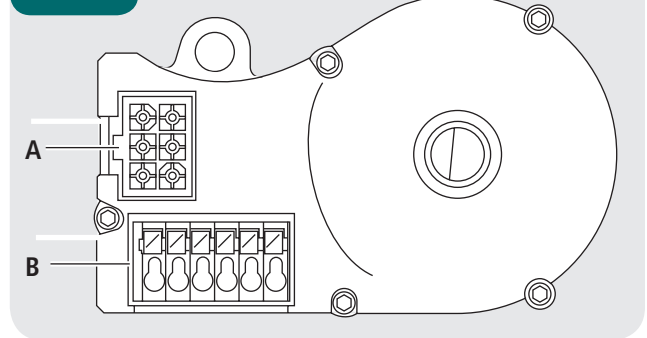

- A: AVE plug (absolute value encoder plug)
- B: AVE plug terminal (absolute value encoder plug terminal)

REFERENCE

Please refer to the control unit operating manual for instructions on setting the end positions.

Wiring allocation, AVE (absolute value encoder) plug

6.4 / 2

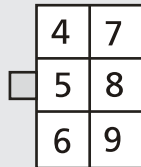

The numbers on the plug are also the wire-numbers.

- 4: Safety circuit input
- 5: RS 485 B
- 6: GND
- 7: RS485 A
- 8: Safety circuit output
- 9: 7...18V_{DC}

AVE (absolute value encoder) plug terminal (7-12)

6.4 / 3

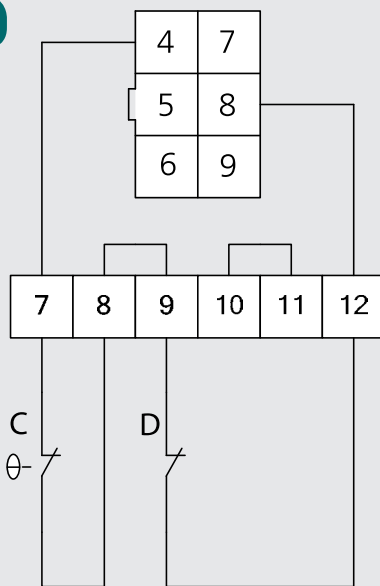

- C: Thermal element in the drive
- D: Manual emergency control
(emergency crank or emergency chain)

6.5 Check the system

Check the direction of travel

➤ Drive the door in the CLOSED direction.
The operator must close the door.

➤ Drive the door in the OPEN direction.
The drive must open the door.

If the direction of movement of the door does not match the button commands, change the direction of rotation.
The direction of movement must then be checked again.

i REFERENCE

Please refer to the control unit operating manual for instructions on changing the direction of rotation.

Check the limit switch settings

➤ Drive the door to the CLOSED end position.
The drive must stop in the desired position.

➤ Drive the door to the OPEN end position.
The operator must stop in the desired position.

➤ Check the seat of the fixing screws.

Check the mechanical functions

After assembling and installing all components the functions of the system must be checked.

- Check all the functions of the system.
- Check that the operator runs smoothly.
- Check whether the operator is leaking oil.

If the operator makes unusual noises or leaks oil:

- The operator must be taken out of service immediately,
- The customer service must be informed.

7. Emergency operation

WARNING!

Improper use may result in serious injury!

To avoid injury, the following points must be observed:

- Emergency operation must only be carried out from a safe standing position.
- Emergency operation must only be carried out when the motor is stationary.
- The system must be disconnected from the power supply during emergency operation.



During maintenance works or in the case of an electrical fault, the door can be moved towards the OPEN or CLOSED positions with the help of the emergency operation equipment.

If the door is moved beyond the CLOSED or OPEN end positions, the drive can no longer be activated electrically.

Operation with emergency hand chain

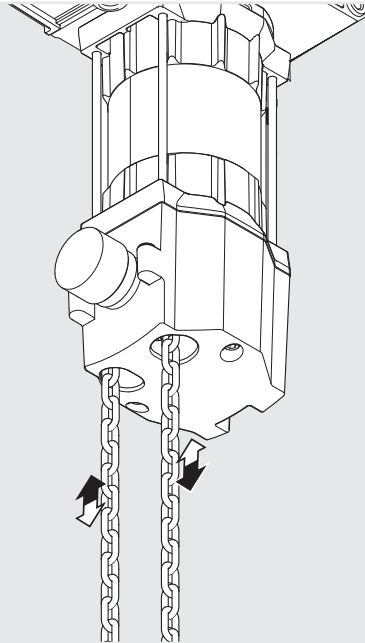
7 / 1





-  Release the emergency hand chain from its fixing.
-  Move the door in the OPEN or CLOSE direction by pulling on the emergency hand chain on the side concerned.

Operation with emergency hand crank

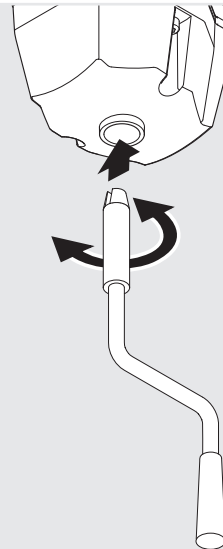
7 / 2



-  Push the emergency hand crank into the operator as far as it will go.
-  Move the door in the OPEN or CLOSE direction by turning the emergency hand crank.
-  Remove the emergency hand crank from the operator after completing emergency manual operation.

Operation with release mechanism

⚠ WARNING!

Risk of serious injury due to uncontrolled movement of the door!

To avoid injury, drive units with a release mechanism require that a fall protection is mounted on the door. Without a fall protection, the door does not comply with directive ASR A1.7.

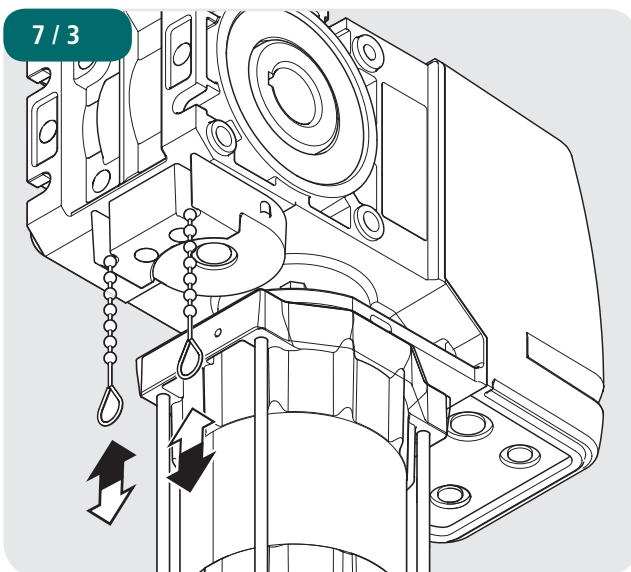

☞ Pull on the red loop.
The gate can be moved manually.

☞ Pull on the green loop.
The door can be moved with the operator.

8. Maintenance

⚠ DANGER!

Danger of fatal electric shock!

☞ Before commencing cabling works, you **MUST** disconnect the drive system from the mains supply. Ensure that the electricity supply remains disconnected throughout the cabling works.

⚠ ATTENTION!

Improper maintenance of the drive can result in property damage!

To avoid damage to the drive and door, the following points must be observed:

- Maintenance must only be carried out by authorized persons.
- Directive ASR A1.7 must be complied with.
- Worn or faulty parts must be replaced.
- Only approved parts must be installed.
- All maintenance work must be documented.

The drive unit has lifetime lubrication and is maintenance-free.

The hollow shaft must be kept rust-free.

☞ Check that all mountings have been securely tightened.
☞ Check the spring tension on the door.
The springs must be adjusted so that they are weight counter-balanced.

- ☞ Check the brake (if available).
- ☞ Check the limit switches and safety switches.
- ☞ Check for noises and oil leaks.
- ☞ Check the mounting of the drive for corrosion.
- ☞ Check the housing for damage.

Faulty parts that have been replaced must be disposed of properly in accordance with the regulations.

9. Technical data

Type (E / KU / KE):	STA 1-11-19 STAC 1-11-19	STA 1-10-24 STAC 1-10-24	STA 1-13-15 STAC 1-13-15	STA 1-12-19 STAC 1-12-19	STA 1-11-24 STAC 1-11-24	STA 1-10-30 STAC 1-10-30
Driving torque (Nm):	110	100	130	120	110	100
Static holding torque (Nm):	600	600	600	600	600	600
Driving motor speed (min -1):	19	24	15	19	24	30
Motor output (kw):	0.37	0.37	0.55	0.55	0.55	0.55
Operating voltage (V):	230 / 400 / 3~	230 / 400 / 3~	230 / 400 / 3~	230 / 400 / 3~	230 / 400 / 3~	230 / 400 / 3~
Mains frequency Hz:	50	50	50	50	50	50
Control voltage: (V):	24	24	24	24	24	24
Nominal motor current (A):	3.5 / 2.0	3.5 / 2.0	3.1 / 1.8	4.1 / 2.4	4.1 / 2.4	3.5 / 2.0
Maximum no. of operating cycles per hour *:	20	20	20	20	20	20
Fuse protection on site (A):	10,0	10,0	10,0	10,0	10,0	10,0
Protection type (IP)	54	54	54	54	54	54
Temperature range (°C)**:	-20 / +60	-20 / +60	-20 / +60	-20 / +60	-20 / +60	-20 / +60
Continuous sound pressure level (dB (A)):	< 70	< 70	< 70	< 70	< 70	< 70
Weight per piece (kg):	15	15	15	15	15	15
Maximum number of revolutions of driven shaft:	20	20	20	20	20	20
Hollow shaft (mm):	25.4	25.4	25.4	25.4	25.4	25.4

* 1 cycle = 1 complete door movement (open and then close the door).
The values given assume an even distribution.

** Temperature ranges < -5 °C: Type of oil and electric heater on request.

Type (E / KU / KE):	STA 1-13-15 HD	STA 1-12-19 HD	STA 1-11-24 HD	STA 1-10-30 HD	STAW 1-7-19 STAWC 1-7-19
Driving torque (Nm):	130	120	110	100	70
Static holding torque (Nm):	600	600	600	600	600
Driving motor speed (min -1):	15	19	24	30	19
Motor output (kw):	0.55	0.55	0.55	0.55	0.37
Operating voltage (V):	230 / 400 / 3~	230 / 400 / 3~	230 / 400 / 3~	230 / 400 / 3~	230 / 1~
Mains frequency Hz:	50	50	50	50	50
Control voltage: (V):	24	24	24	24	24
Nominal motor current (A):	3.1 / 1.8	3.0 / 1.7	3.0 / 1.7	3.0 / 1.7	6.2
Maximum no. of operating cycles per hour *:	30	30	30	30	8
Fuse protection on site (A):	10,0	10,0	10,0	10,0	10,0
Protection type (IP)	54	54	54	54	54
Temperature range (°C)**:	-20 / +60	-20 / +60	-20 / +60	-20 / +60	-20 / +60
Continuous sound pressure level (dB (A)):	< 70	< 70	< 70	< 70	-
Weight per piece (kg):	23	23	23	23	23
Maximum number of revolutions of driven shaft:	20	20	20	20	20
Hollow shaft (mm):	25.4	25.4	25.4	25.4	25.4

* 1 cycle = 1 complete door movement (open and then close the door).
 The values given assume an even distribution.

** Temperature ranges < -5 °C: Type of oil and electric heater on request.

Technical data

STA/STAW 1 E

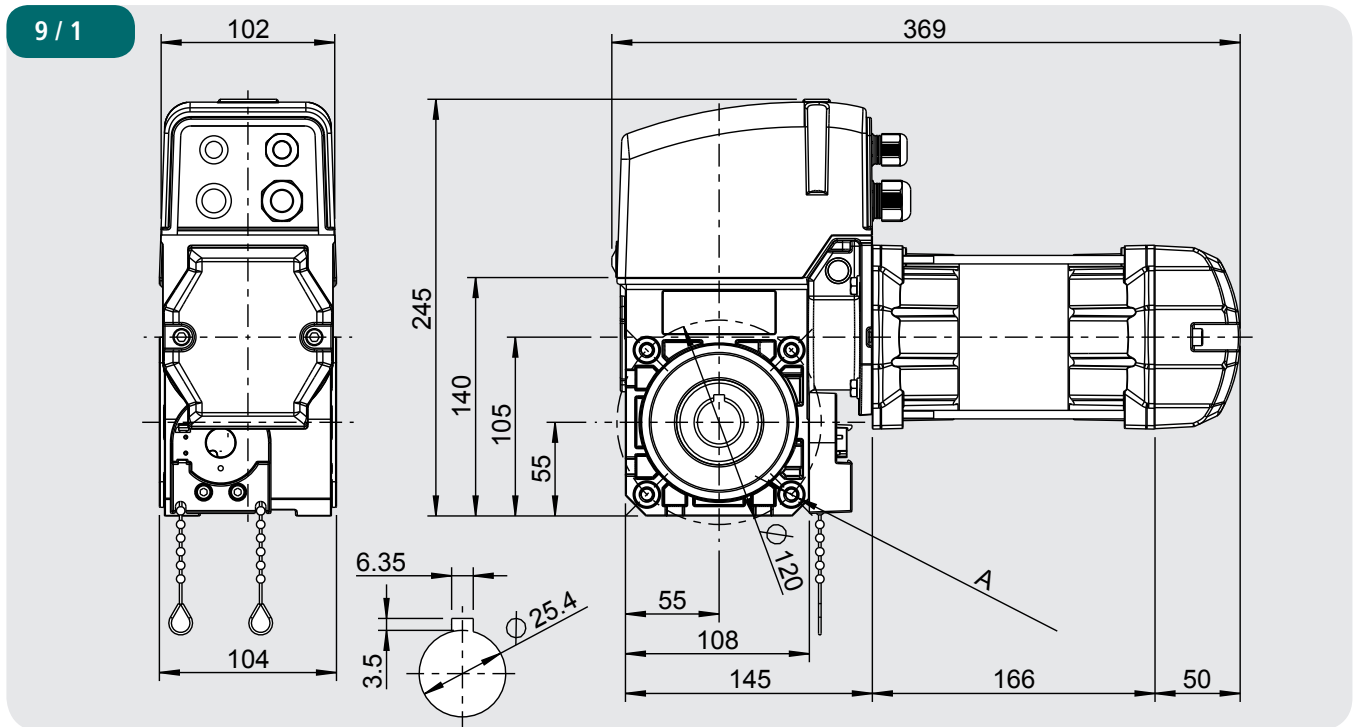

A 4x M8x16 deep, on both sides

STA/STAW 1 KE

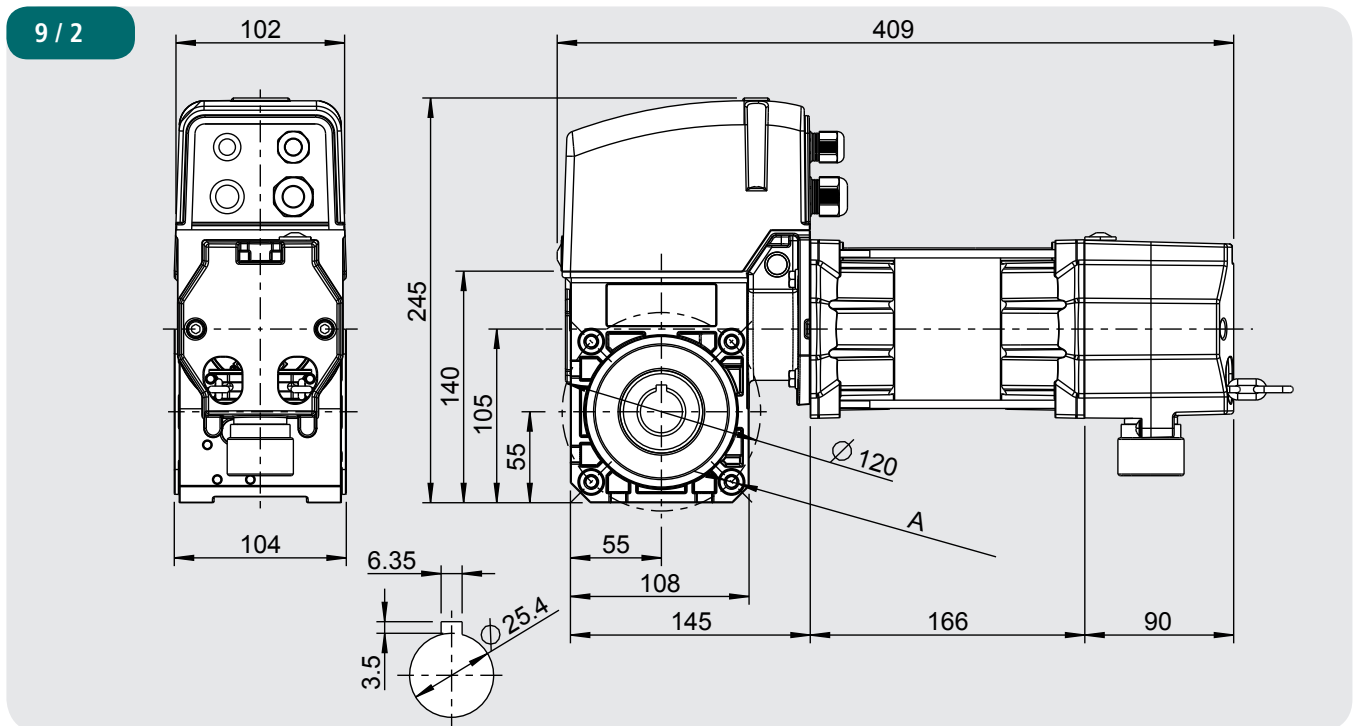

A 4x M8x16 deep, on both sides

STA/STAW 1 KU

9 / 3

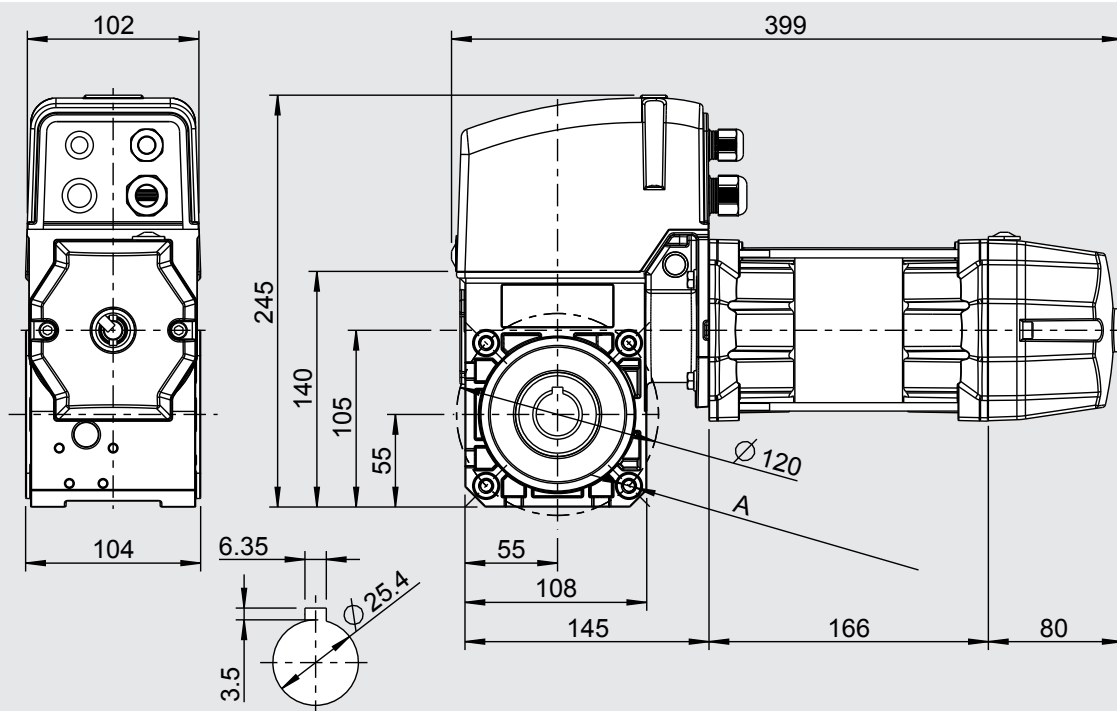

A 4x M8x16 deep, on both sides

STA/STAW 1 E - HD

9 / 4

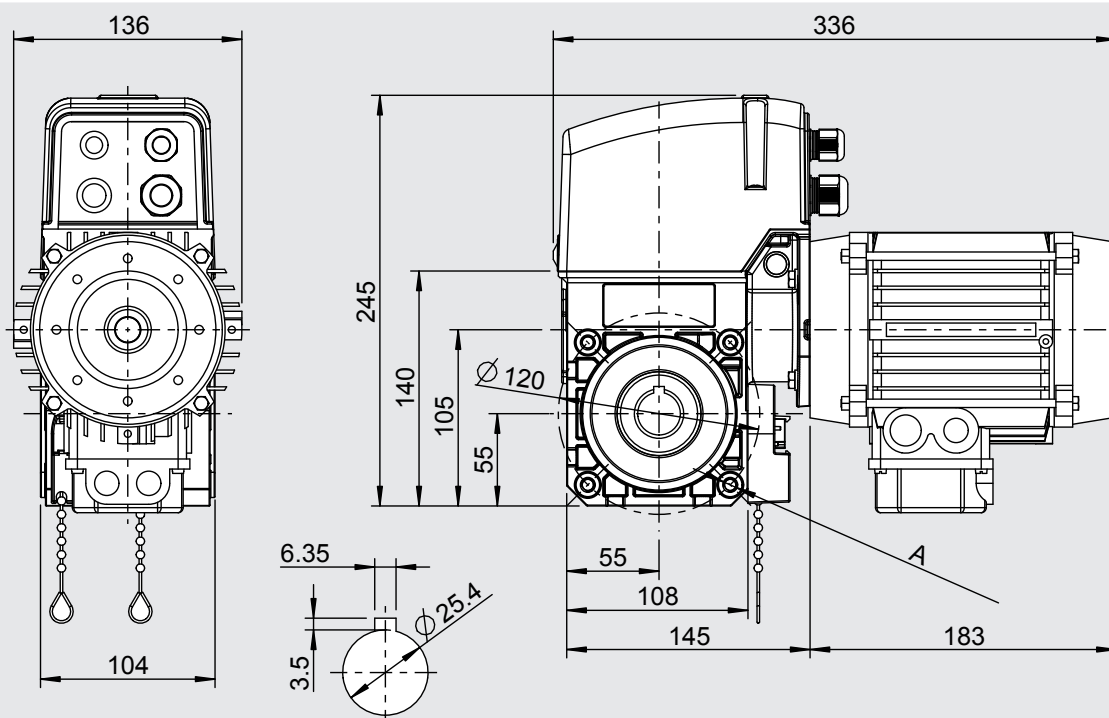

A 4x M8x16 deep, on both sides

Technical data

STA/STAW 1 KE - HD

9 / 5

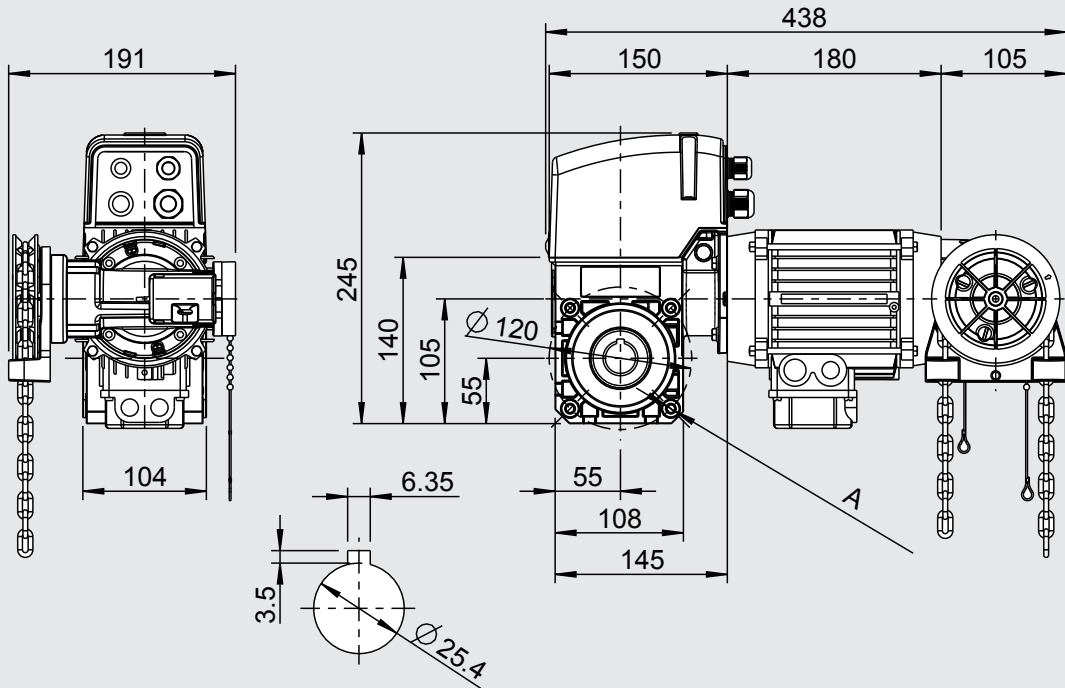

A 4x M8x16 deep, on both sides

STA/STAW 1 KU - HD

9 / 6

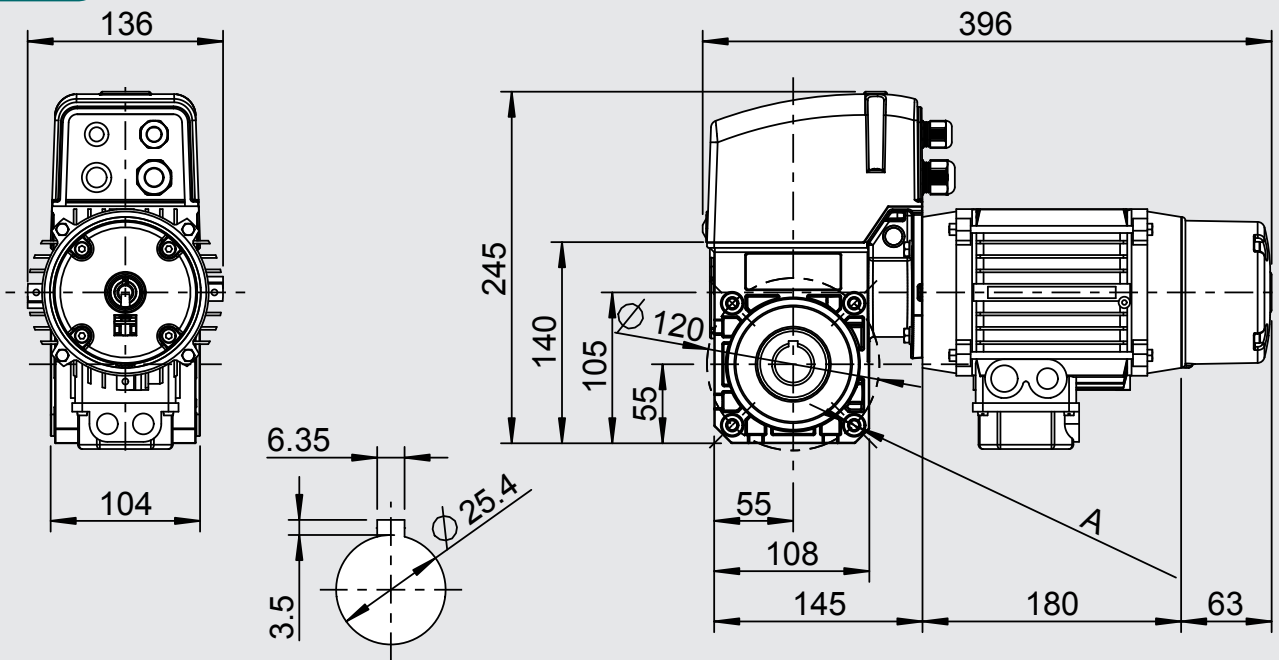

A 4x M8x16 deep, on both sides

STAC/STAWC 1 E

9 / 7

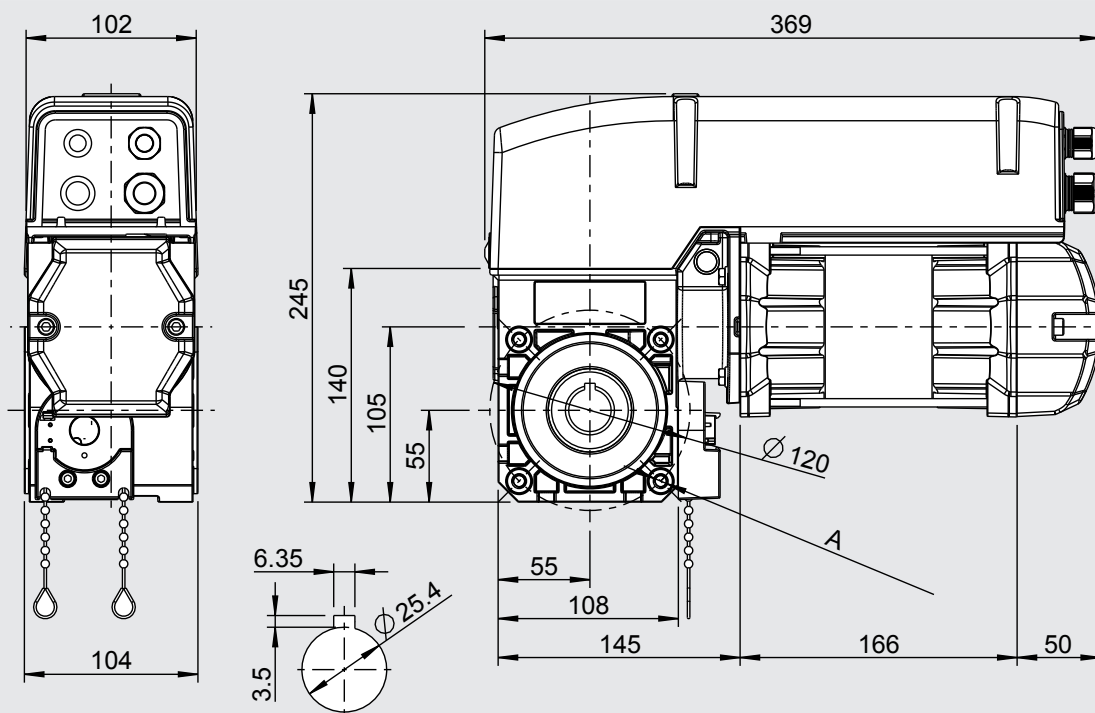

A 4x M8x16 deep, on both sides

STAC/STAWC 1 KE

9 / 8

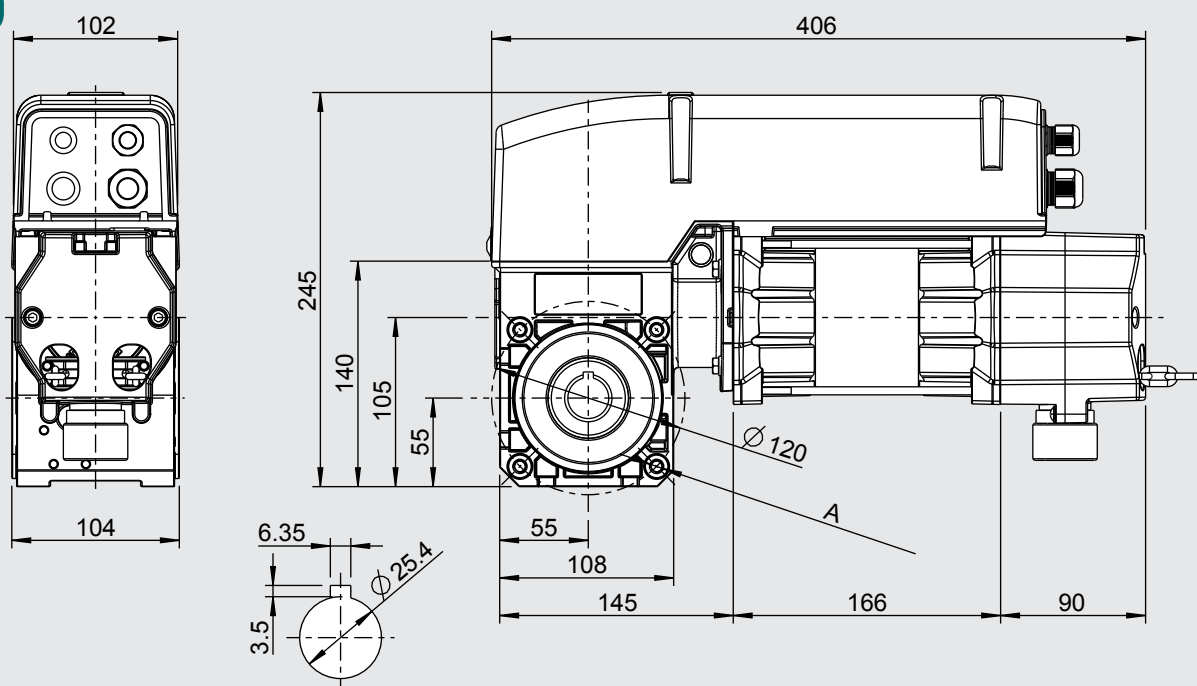

A 4x M8x16 deep, on both sides

Technical data

STAC/STAWC 1 KU

9 / 9

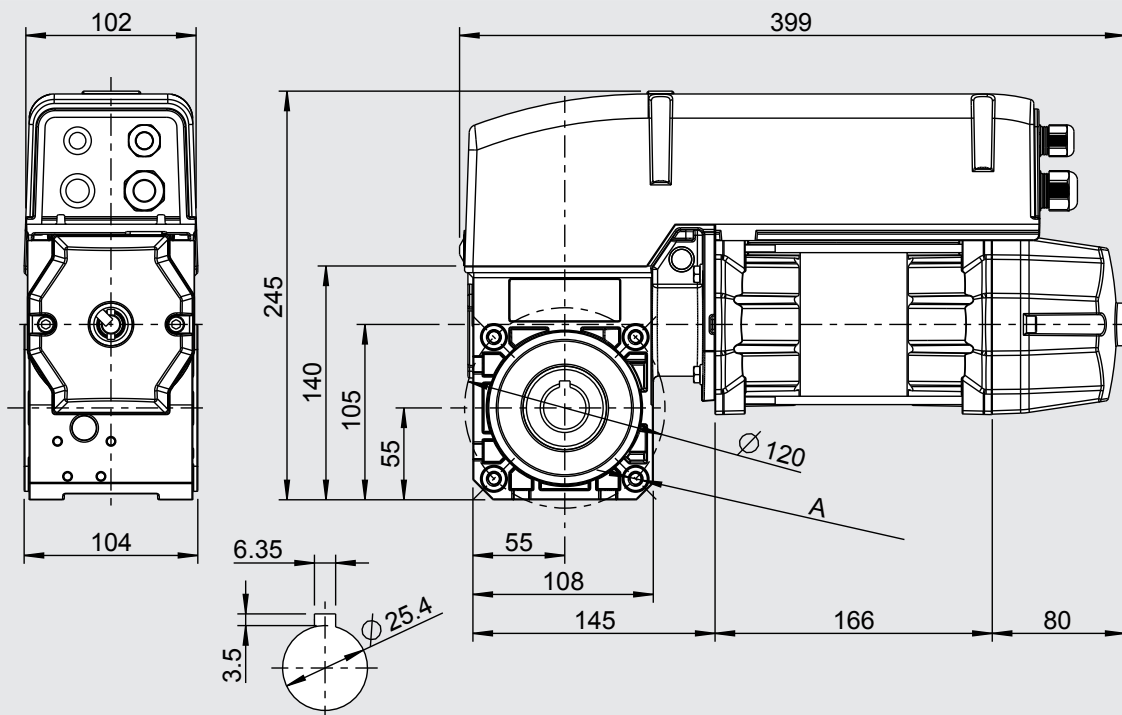

A 4x M8x16 deep, on both sides

10. Manufacturer's Declaration

Declaration of incorporation

within the context of Machinery Directive 2006/42/EC for incorporation in an incomplete machine according to Appendix II, Part 1B

MFZ Antriebe GmbH & Co.KG
Neue Mühle 4
D - 48739 Legden

Declaration of conformity

within the context of the directives on Electromagnetic Compatibility 2014/30/EU and RoHS 2011/65/EU

We hereby declare that the following listed product

Product designation: **Sectional door operator**

Type designation: **STA1**

as an incomplete machine specified exclusively for integration with a door system and designed, constructed, and produced in conjunction with the following directives:

Machinery Directive 2006/42/EC
Electromagnetic Compatibility Directive 2014/30/EU
RoHS Directive 2011/65/EU

Furthermore, the requirements of the Low-Voltage Directive 2014/35/EU are met according to Appendix I Part 1.5.1 of the Machinery Directive 2006/42/EC.

Applied and consulted standards:

EN 12453 Doors - Safety in use of power operated doors: Requirements and test methods
EN 12604 Doors - Mechanical aspects: Requirements and test methods
EN 60335-1 Household and similar electrical appliances - Safety - Part 1: General requirements
EN 60335-2-103 Household and similar electrical appliances - Safety - Part 2-103: Particular requirements for drives for gates, doors and windows
EN 61000-6-2 Electromagnetic compatibility (EMC) - Part 6-2: Generic standards - Immunity standard for industrial environments
EN 61000-6-3 Electromagnetic compatibility (EMC) - Part 6-3: Generic standards - Emission standard for residential, commercial and light-industrial environments

The special technical documents were created according to Appendix VII Part B of the Machinery Directive (2006/42/EC).

We are obligated to transmit these to market monitoring agencies in a timely manner upon justified request in electronic form.

Authorised representative for compiling the technical documents:

MFZ Antriebe GmbH & Co. KG - Neue Mühle 4 - 48739 Legden - Germany

Incomplete machines within the context of EC Directive 2006/42/EC are therefore only specified for incorporation with other machines or with other incomplete machines or systems or combined with them to form a machine within the contact of the directive indicated above. For this reason, this product may only be commissioned once it has been determined that the complete machine /system into which it has been incorporated corresponds with the indicated EC guidelines.

In case of changes to the product that are not confirmed by us, this declaration is void.

Legden, dated 01.07.2018



Dirk Wesseling, General Manager

